

S P R O C K E T S

1/2" x 3/16"

for roller chains in compliance with DIN 8187 ISO/R 606

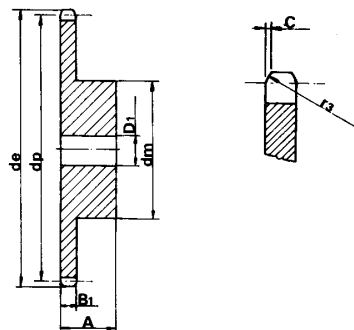

SPROCKET mm

TOOTH RADIUS r_3	13
RADIUS WIDTH C	1.3
SPROCKET TOOTH WIDTH B_1	4.5

CHAIN mm

PITCH	12.7
INTERNAL WIDTH	4.88
ROLLER - \emptyset	7.75

MATERIAL: C 45 UNI 7847

Z	d_e	d_p	SINGLE		
			d_m	D_1	A
8	38.5	33.18	21	8	14
9	41.5	37.13	25	8	14
10	46.2	41.10	28	8	14
11	49.6	45.07	31	8	16
12	53.9	49.07	35	8	16
13	58.4	53.06	39	8	16
14	62.8	57.07	43	8	16
15	66.8	61.09	47	8	16
16	70.9	65.10	50	10	18
17	74.9	69.11	50	10	18
18	78.9	73.14	50	10	18
19	82.9	77.16	50	10	18
20	88.9	81.19	50	10	18
21	91.0	85.22	60	12	20
22	95.0	89.24	60	12	20
23	99.0	93.27	60	12	20
24	103.0	97.29	60	12	20
25	107.1	101.33	60	12	20
26	111.2	105.36	70	16	20
27	115.4	109.40	70	16	20
28	119.4	113.42	70	16	20
29	123.4	117.46	70	16	20
30	127.5	121.50	70	16	20
31	131.5	125.54	70	16	20
32	135.5	129.56	70	16	20
33	139.6	133.60	70	16	20
34	143.6	137.64	70	16	20
35	147.6	141.68	70	16	20
36	151.7	145.72	70	16	25
37	155.7	149.76	70	16	25
38	159.8	153.80	70	16	25
39	163.8	157.83	70	16	25
40	167.8	161.87	70	16	25

P L A T E W H E E L S

1/2" x 3/16"

for roller chains in compliance with DIN 8187 ISO/R 606

The wheel disc size is increased by $h = 6\text{mm}$ starting from Z.90

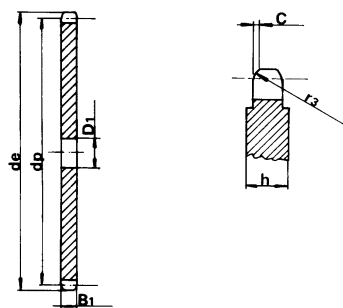

PLATEWHEEL mm

TOOTH RADIUS r_3	13
RADIUS WIDTH C	1.3
PLATE TOOTH WIDTH B_1	4.3 ± 0.2

CHAIN mm

PITCH	12.7
INTERNAL WIDTH	4.88
ROLLER - \emptyset	7.75

Z	d_e	d_p	S	Z	d_e	d_p	S
			D_1				D_1
8	38.5	33.18	8	43	179.5	173.99	16
9	41.5	37.13	8	44	183.5	178.03	16
10	46.2	41.10	8	45	187.5	182.07	16
11	49.6	45.07	8	46	191.6	186.10	20
12	53.9	49.07	8	47	195.6	190.14	20
13	58.4	53.06	8	48	199.7	194.18	20
14	62.8	57.07	8	49	203.7	198.22	20
15	66.8	61.09	8	50	207.8	202.26	20
16	70.9	65.10	10	51	211.8	206.30	20
17	74.9	69.11	10	52	215.9	210.34	20
18	78.9	73.14	10	53	219.9	214.37	20
19	82.9	77.16	10	54	224.0	218.43	20
20	86.9	81.19	10	55	228.0	222.46	20
21	91.0	85.22	10	56	232.1	226.50	20
22	95.0	89.24	10	57	236.1	230.54	20
23	99.0	93.27	10	58	240.2	234.58	20
24	103.0	97.29	10	59	244.2	238.62	20
25	107.1	101.33	10	60	248.2	242.66	20
26	111.2	105.36	12	62	256.7	250.75	20
27	115.4	109.40	12	64	264.8	258.82	20
28	119.4	113.42	12	65	268.8	262.86	20
29	123.4	117.46	12	66	272.9	266.90	25
30	127.5	121.50	12	68	280.9	274.99	25
31	131.5	125.54	12	70	289.0	283.07	25
32	135.5	129.56	12	72	297.1	291.16	25
33	139.6	133.60	12	76	313.3	307.33	25
34	143.6	137.64	12	78	321.4	315.40	25
35	147.6	141.68	12	80	329.4	323.48	25
36	151.7	145.72	16	85	349.7	343.70	25
37	155.7	149.76	16	90	369.9	363.90	25
38	159.8	153.80	16	95	390.1	384.10	25
39	163.8	157.83	16	100	410.3	404.31	25
40	167.8	161.87	16	110	450.7	444.74	25
41	171.4	165.91	16	114	466.9	460.90	25
42	175.4	169.95	16	120	491.2	485.16	25
				125	511.4	505.37	25